

H6350-09PSW0000

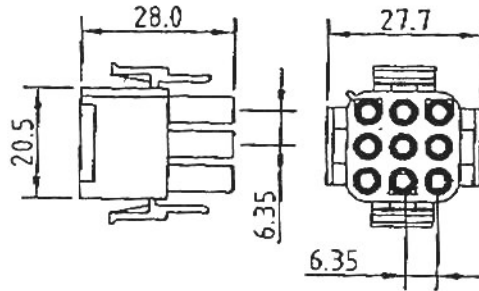

H6350-15PSW0000

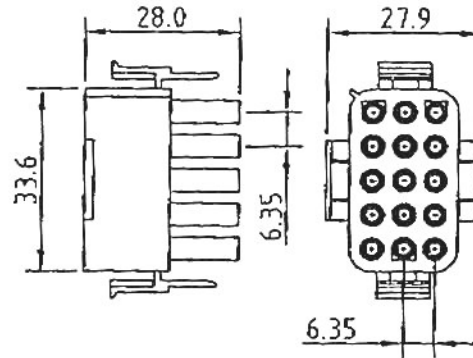

H6350-12PSW0000

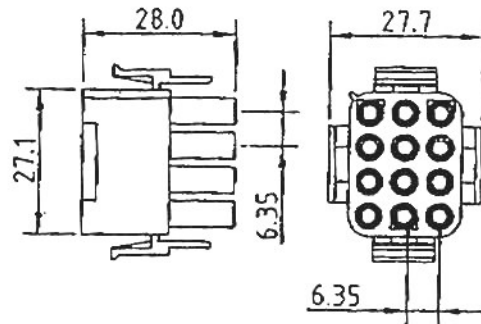

SPECIFICATION

Pitch Between Poles: 6.35mm

Current Rating: 13A

Voltage Rating: 600V

Contact Resistance: 5MΩ (Max)

Insulation Resistance: 1000M Ω Min.

Withstand Voltage: 1500V AC / 1 Minute.

Temperature Range: -25°C to +85°C

Applicable Wire: AWG#14 to #20

FEATURES

Available Number Of Circuits: 1 to 15

Material: Nylon 66, UL94V-2

Accepts: T6350 Crimp Terminal

Mates: H6351 Series

玄茂科技股份有限公司
HSUAN MAO TECHNOLOGY CO., LTD.

UNIT

SCALE

PART NAME

MM

2 : 1

6.35mm Pitch Wire to Wire
Male Housing(3*3P、3*4P、3*5P)

APPD.

CKD.

TOLERANCE

PART NO.

REV.

制表日: 2002/12/04

DRAWING.

APPROVED

± 0.5

H6350-XXPTW000

A

Jane